

FIXED WINDOW

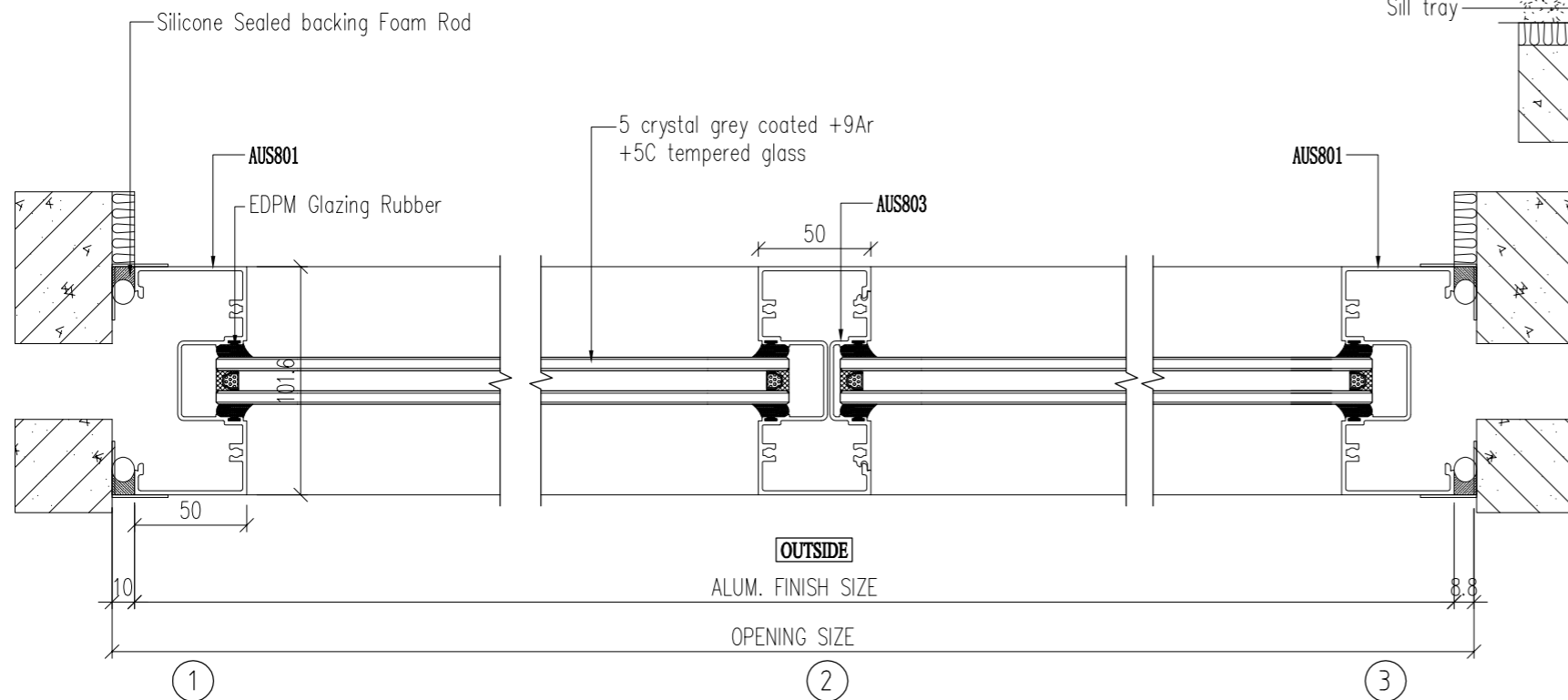

- GENERAL NOTES**
1. All dimensions shown are in millimetres unless otherwise noted.
 2. All elevations shown are viewed from outside looking in.
 3. Dimensions provided are taken from the provided architectural drawings and are to be confirmed onsite prior to manufacture.
 4. LuxWin to be notified of any onsite discrepancies in order for drawing modifications to occur.

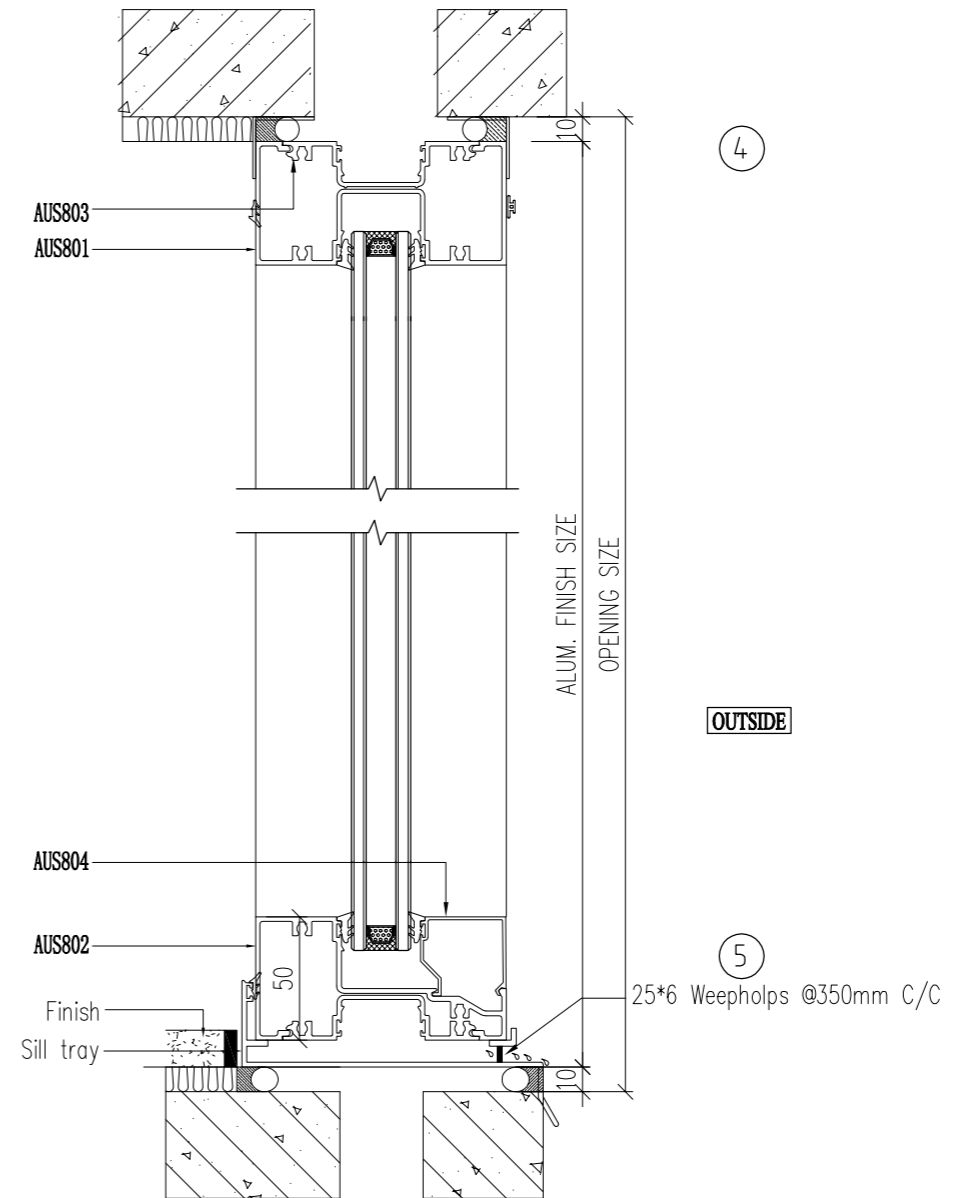

ADD: 8/1 Pitt Way, Booragoon
TEL: 9494 0000

Email: sales@luxwin.com.au
Web: www.luxwin.com.au

FIXED WINDOW

Do not scale drawings. All the dimensions should be checked on site by contractors and clarified by LuxWin. The ownership of the drawings must be obtained from LuxWin before any construction of drawings can commence.